

BetaTurn

BetaTurn BlockTurner

BetaTurn Block Turner

**The world's choice in cheese
packaging and handling systems**

The BetaTurn can be installed utilizing existing conveyors; alternatively in-feed and out-feed conveyors, built to a critical hygiene standard, can be supplied as an optional extra. The BetaTurn can rotate to any angle and has a bi-directional conveyor. This makes it adaptable to any factory requirement.

The BetaTurn is extremely user friendly and is easy to install and operate. Originally designed to smoothly and efficiently rotate 20kg blocks of cheese, the BetaTurn can easily be adapted to handle other package configurations.

Beteturn Plus

**The Betaturn can rotate to any angle and has a bi-directional conveyor. This makes it adaptable to any factory requirement

- In line Multiangle block turner
- Designed for 20kg blocks of cheese
- Construction materials are T304 stainless steel and engineered plastics
- Adjustable Swivel Feet
- Manufactured to International Standards
- Worldwide spares and service available direct from factory.
- Single/two phase power supply needed. No air supply is needed.

Conveyor

- Fitted with flush grid polypropylene belt
- Forward and reverse belt travel
- VSD controlled AC Motor - 0.18kW
- Nominal Belt Speed 20 m/min

Rotating actuator

- Smooth and safe motion
- Rotatable to any angle.
- Forward and reverse travel
- VSD controlled AC Motor with encoder - 0.18kW

Electrical

- IP65 minimum
- Sensors for block positioning
- Allen Bradley PLC
- Start, Stop, Reset and Estop Buttons

Options for PLUS

- HMI
- Speed control
- Detection of Seal for outgoing direction
- Integration into plant via ethernet

Beteturn SD

- The Betaturn SD can only rotate to two positions and has a bi-directional conveyor.
- In line 2 position block turner - 90° or 180°
- Designed for 20kg blocks of cheese
- Construction materials are T304 stainless steel and engineered plastics
- Adjustable Swivel Feet
- Manufactured to International Standards
- Worldwide spares and service available direct from factory.
- Single/two phase power & Pneumatic supply needed.

Conveyor

- Fitted with flush grid polypropylene belt
- Forward and reverse belt travel
- VSD controlled AC Motor – 0.18kW
- Nominal Belt Speed 20 m/min

Rotating actuator

- Smooth and safe motion
- Rotatable to two selectable positions of 0°-90° or 0°-180°.
- Forward and reverse travel
- Pneumatic Controlled

Electrical

- IP65 minimum
- Sensors for block positioning
- Allen Bradley PLC
- Start, Stop, Reset and Estop Buttons

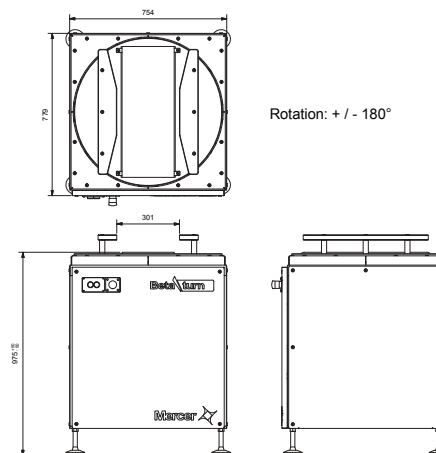

USA
UK
Australia
New Zealand

✉ enquiries@hadencustance.com
www.hadencustance.com

Your local agent: